

Product: Concrete block for SON17

Product code: 40

Roof conductor fastener

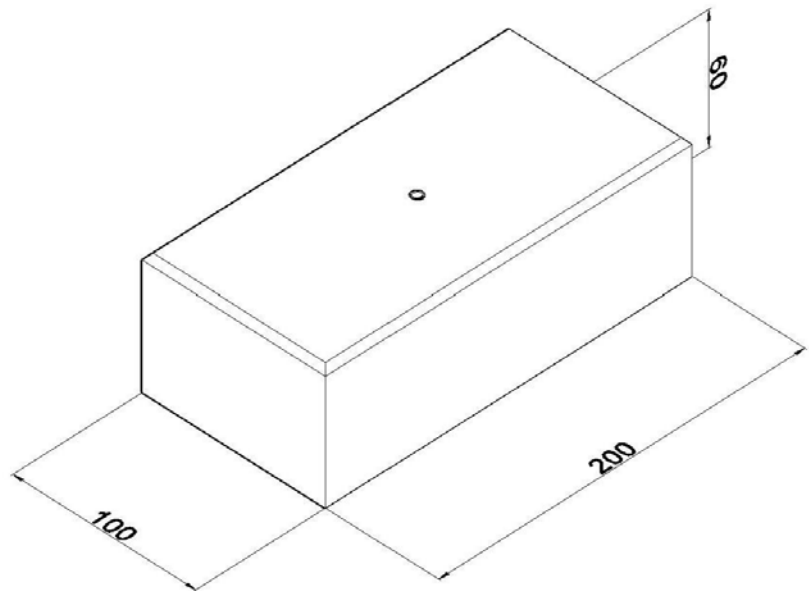

Standard:	EN 62561-4:2017: Lightning protection system components (LPSC) - Part 4: Requirements for conductor fastener
Dimensions:	Length: 200 mm
	Width: 100 mm
	Height: 60 mm
	Conductor diameter:
	Weight: 3 kg
Material:	Concrete