

Product: ZON07

Product code: 20526

Drivable measuring cabinet

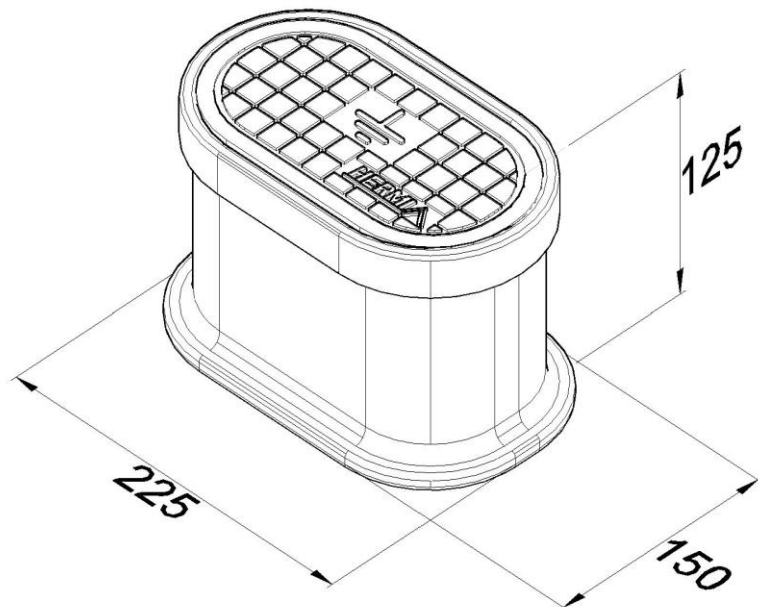

Standard:	EN 62561-5:2017: Lightning protection system components (LPSC) - Part 5: Requirements for earth electrode inspection housings and earth electrode seals
Dimensions:	Length: 225 mm
	Height: 125 mm
	Depth: 150 mm
	Weight: 2,10 kg
Material:	Polyetilen - cast iron