

Product: KON21

Product code: 200212

Contact clamp for lightning conductor

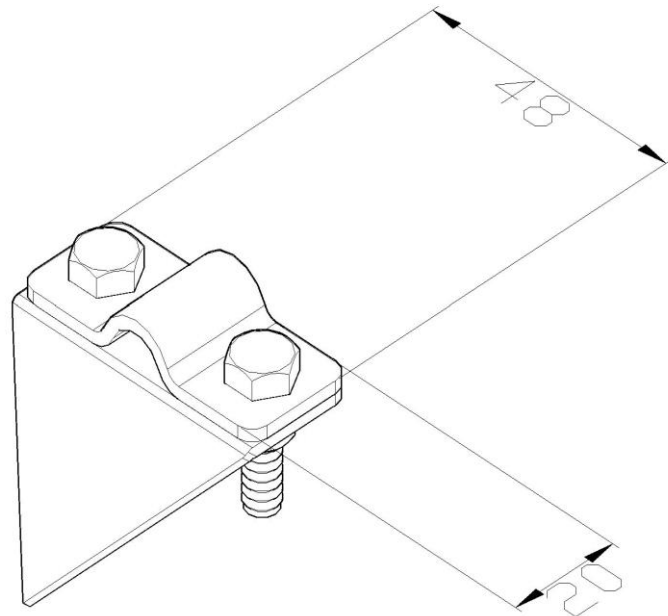

| | |
|-------------------------------------------|-----------------------------------------------------------------------------------------------------------------|
| Standard: | EN 62561-1:2017: Lightning Protection System Components (LPSC) - Part 1: Requirements for connection components |
| Dimensions: | Length: 20 mm |
| | Width: 48 mm |
| | Height: |
| | Weight: 0,06 kg |
| | Conductor dimensions 1: $\phi 8-10$ mm |
| | Conductor dimensions 2: |
| Material: | stainless steel |
| Withstand lightning current class: | N |