

Product: NKP-VE 11D/OMEGA

Product code: 88707191

Connecting element

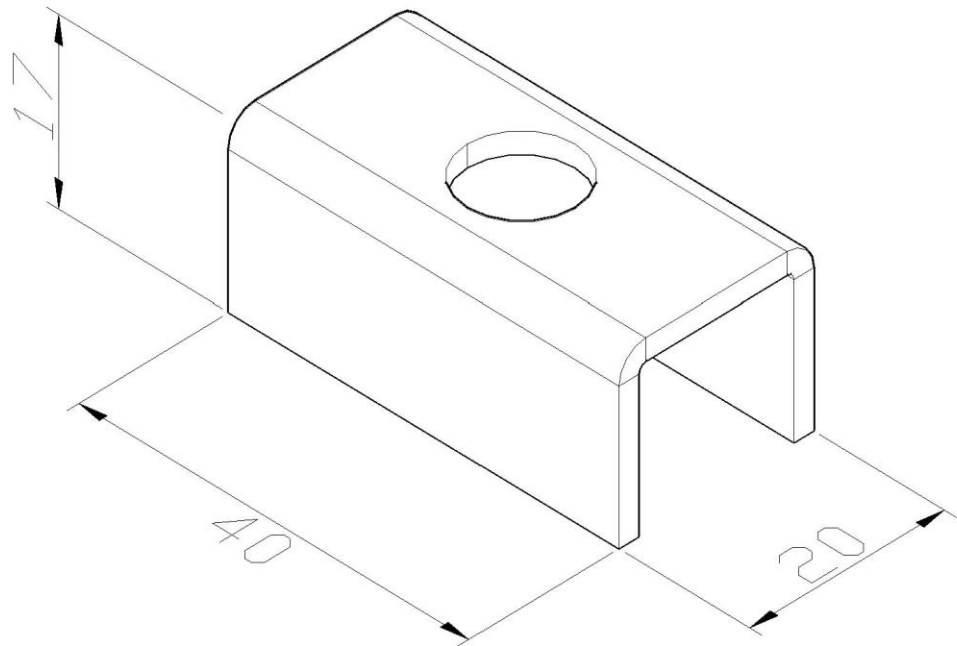

Standard:	EN 61537:2007 Cable management - Cable tray systems and cable ladder systems
Dimensions:	Length: 40 mm
	Width: 20 mm
	Height: 17 mm
	Metal thickness: 2 mm
Maximum load:	
Weight:	0,3 kg
Material:	Galvanised steel
Contribution to fire:	Non-flame propagating system
Electrical characteristics:	Electrically conductive system
Electrical continuity:	Yes
Corrosion resistance:	Class 3
Temperature:	Min: -20°C; Max: +105°C