

Product: LOP-P 16 A

Product code: 301507

Attachment kit for placing lightning rods

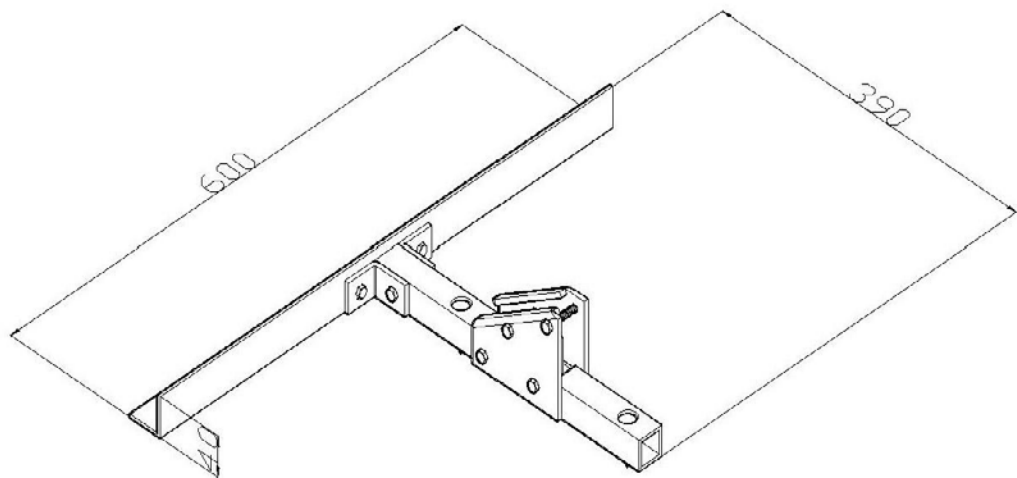

Standard:	EN IEC 62561-2:2018: Lightning Protection System Components (LPSC) - Part 2: Requirements for conductors and earth electrodes
Dimensions:	Length: 600 mm
	Width: 390 mm
	Height: 40 mm
	Diameter:
Material:	Weight: 1,15 kg
	Aluminium