

Product: LOP-P20

Product code: 301523

Clamp for fastening the attachment kit

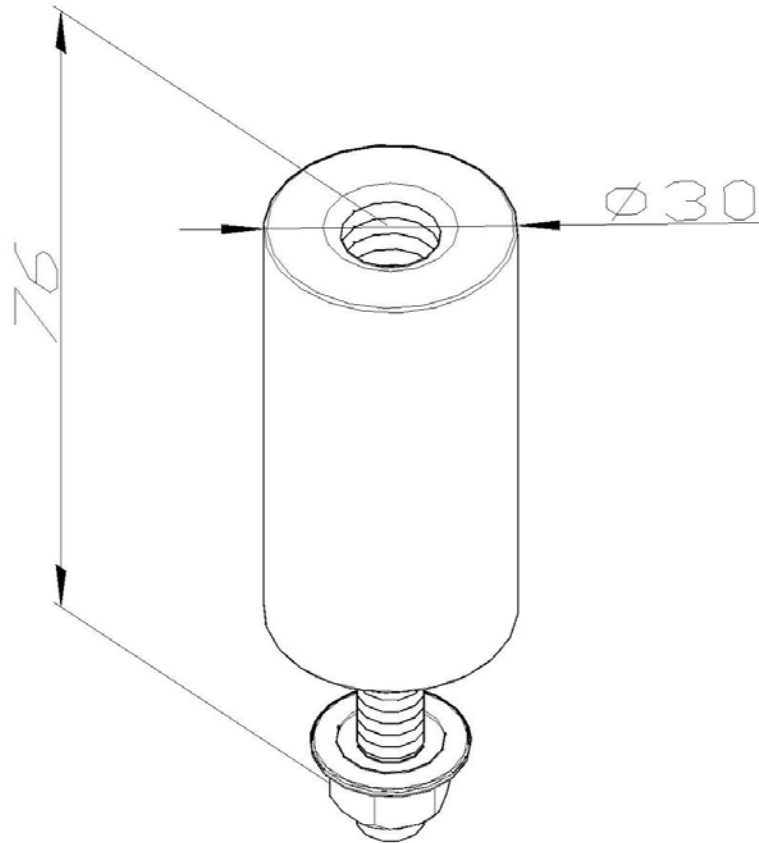

Standard:	EN IEC 62561-2:2018: Lightning Protection System Components (LPSC) - Part 2: Requirements for conductors and earth electrodes
Dimensions:	Length:
	Width:
	Height: 76 mm
	Diameter: $\varnothing 30$ mm
	Weight: 0,1 kg
Material:	Aluminium