

**Product:** LOP-P34 A

**Product code:** 301537

Bracket/attachment element

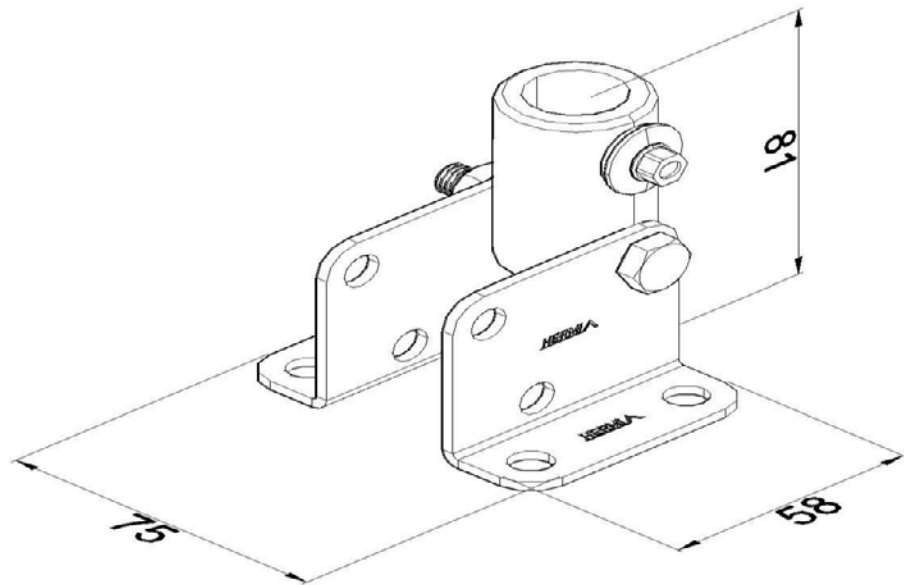

<b>Standard:</b>	EN IEC 62561-2:2018: Lightning Protection System Components (LPSC) - Part 2: Requirements for conductors and earth electrodes
<b>Dimensions:</b>	Length: 75 mm
	Width: 58 mm
	Height: 81 mm
	Weight: 0,28 kg
<b>Material:</b>	Aluminium - stainless steel